

INCH SCALE

0 1 2 3 4 5 6

B

A

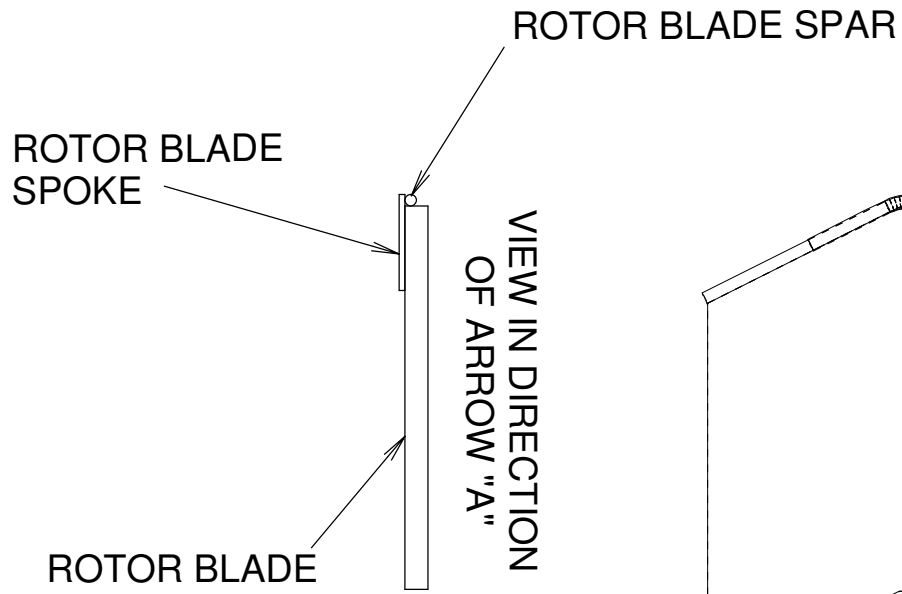

BUILD 4 OF THESE ASSEMBLIES.

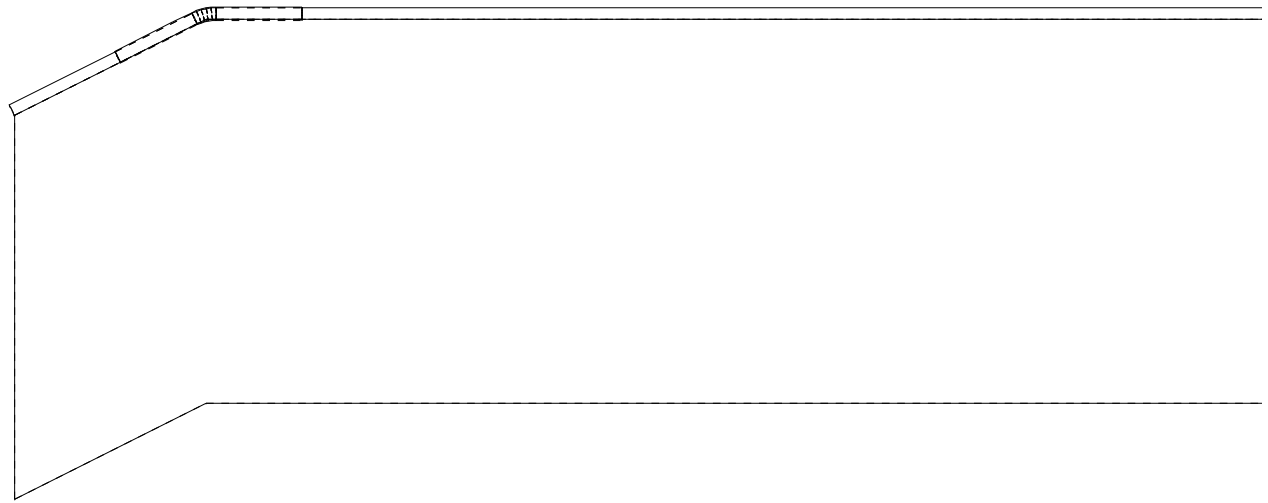

BLADE / SPOKE OVERLAP

1in

A

A

**DESIGNED BY LEAD**  
**CAD BY DZ1SFB**

ASSEMBLE HUB FROM 2 ROTOR HUB/REINFORCEMENT  
ASSEMBLIES WITH 3/32" BRASS TUBE

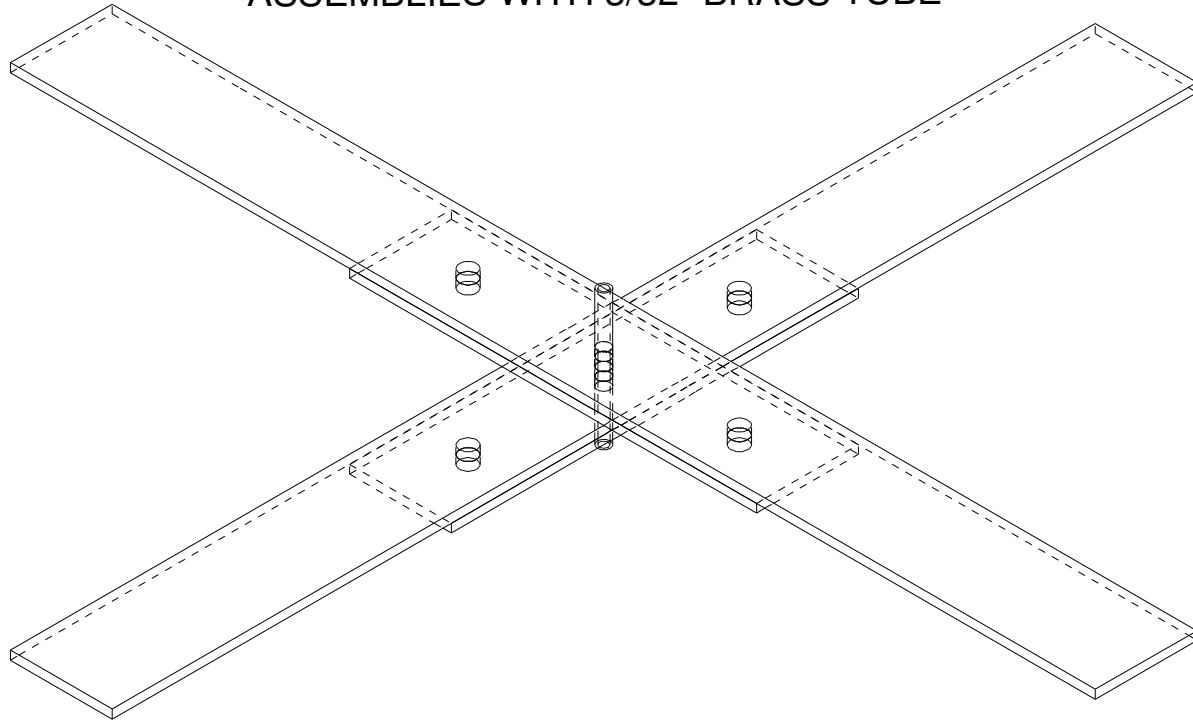

B

A

**HEADFEATHER**

TITLE			
<b>APACHE AG-64 ROTOR ASSEMBLY</b>			
SIZE	CAGE CODE	DWG NO	REV
C		COMMERCIAL RIGHTS RESERVED 21-FEB-2010	
SCALE		SHEET	

ROTOR PLAN VIEW 1/2 SCALE

D

C

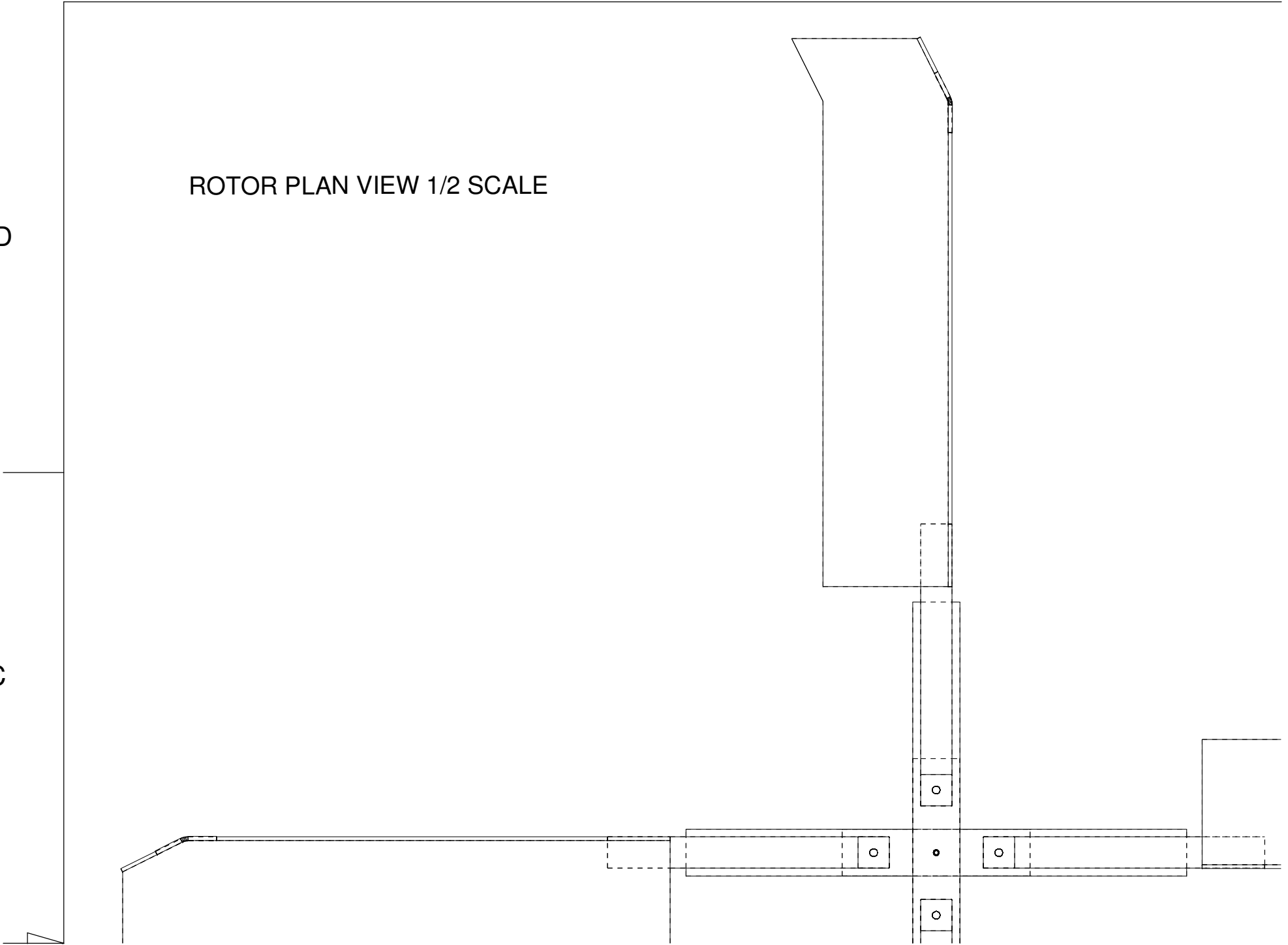

## ROTOR BUILDING INSTRUCTIONS

- 1) Make hubs and blades
- 2) Assemble rotor blade spar, tip weight, and joiner.  
Then glue LE spar assemblies to blades flush with the bottom of rotor blades. 4 assemblies required.
- 3) Assemble hub and reinforcement assemblies. 2 required.
- 4) stack the individual 2 blade rotors at 90 degrees
- 5) Insert 3/32" x 1" brass tube spindle bearing,  
glue in place with cone fillet glue on top and bottom
- 6) Bolt one blade assembly to each spoke of the hub  
with 3mm bolts and nuts.

ROTOR TIP WEIGHT  
1/16" MUSIC WIRE 1  
4 REQUIRED

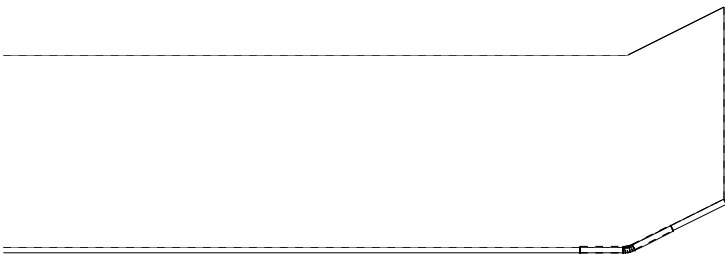

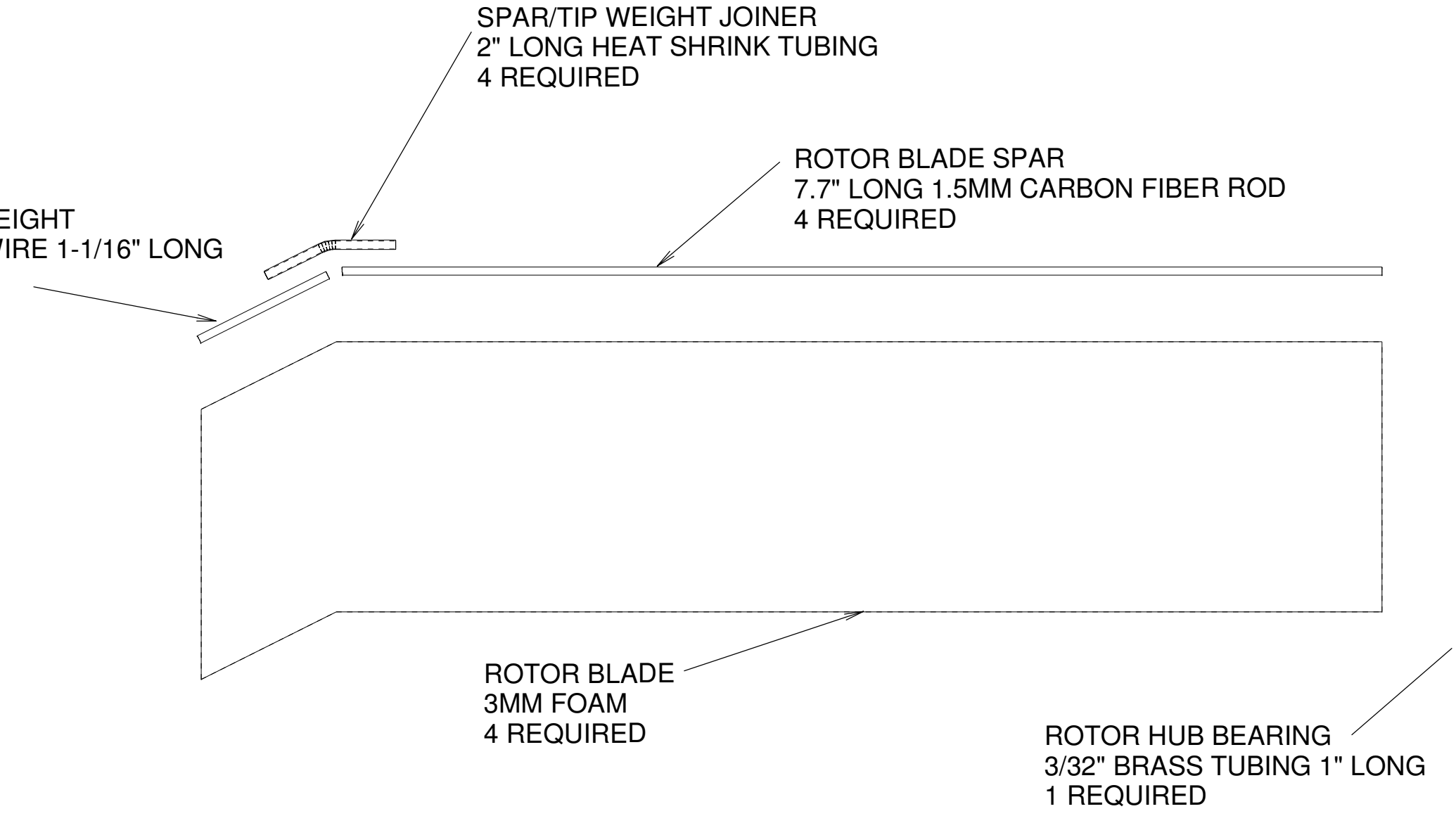

STACK HUB ON TOP OF REINFORCEMENT

1/8" HOLES

ROTOR HUB 1/16" PLYWOOD  
3/4" X 8" - 2 REQUIRED

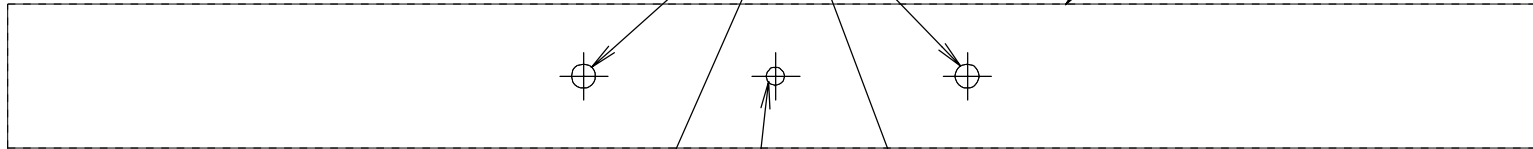

D

ROTOR HUB REINFORCEMENT  
1/16" PLYWOOD 3/4" X 3"  
2 REQUIRED

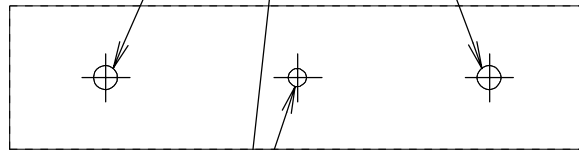

3/32" HOLES

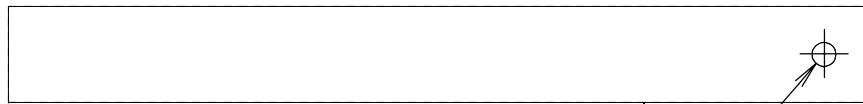
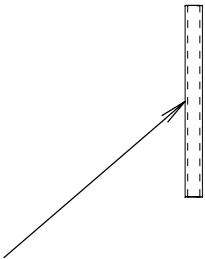

ROTOR BLADE SPOKE 1/32" PLY  
.5" X 4-1/2" - 4 REQUIRED

1/8" HOLE

STACK REINFORCEMENT ON TOP OF SPOKE

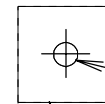

1/8" HOLE  
ON CENTER

ROTOR BLADE SPOKE  
REINFORCEMENT 1/32"  
PLYWOOD - .5" X .5"  
4 PCS REQUIRED

C